

MFH03 / 系列

MFH03 SERIES

- 使用高剛性材質，在高速加工時提高性能。
The hard steel design to perfect the performance in high feed machining
- 增加排屑量，提高生產效率
Increased chip evacuation and improve productivity
- 雙面4個切削刃更符合經濟效益。
Works efficiently with 4 insert edges
- 高進給系統不僅可降低切削阻力亦可進行多樣加工，如：斜向加工、平面加工、曲面加工...等。
The high feed milling cutter offers low resistance and it is applicable to multi-functional, such as ramping, face milling and helical machining...etc.



外徑出水刀桿 EXTERNAL TURNING TOOL WITH COOLANT

- 高剛性材質、水孔設計，可延長刀片使用壽命。
The hard steel and coolant design to enhance the insert life
- 高壓出水精確地沖擊切削刃，可將切屑沖成小片狀讓切屑更容易排除。
Coolant jets precisely to increase chip evacuation
- 走心式刀，提高小型加工效率。
Applicable to small diameter and improve productivity
- 螺絲鎖固構造，替換刀片快速。
Quick insert replacement due to the screw design





弘展切削工具有限公司 HON JAN CUTTING TOOLS CO., LTD.

◆ 台灣總公司

台中市429神岡區豐工南路20號
No.20, Fenggong S. Rd., Shengang Dist.,
Taichung City 429, Taiwan
TEL : 886-4-25291553 FAX : 886-4-25232792
E-mail : info@shangintool.com

◆ 東莞市大井精密刀具有限公司

廣東省東莞市長安鎮烏沙長榮國際五金廣場M30-1
TEL : 86-0769-85642774 / 86-0769-85642784
FAX : 86-0769-85642794

◆ 大陸辦事處

廣東省東莞市長安鎮
TEL : 86-0769-85376529 / 86-0769-85842001~2
FAX : 86-0769-85844291



SHAN GIN CUTTING TOOLS



※完善售後服務
追求精緻卓越

替換式刀刃 切削工具

INDEXABLE
INSERT
CUTTING TOOLS



Perfect your need

www.shangintool.com

內徑車刀 BORING BARS

BORING BARS
內徑車刀











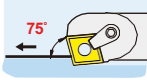

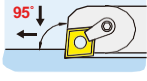

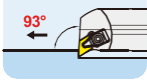





TOOL HOLDERS
外徑車刀











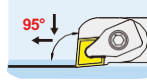











THREADING & GROOVING
牙刀 & 開槽刀

MILLING
銑刀









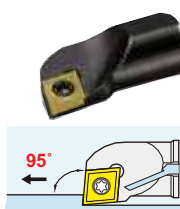

BORING TOOLS COMPONENTS
孔加工

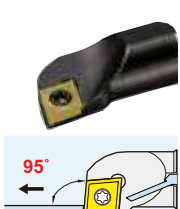

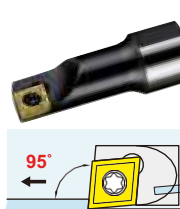

SPARE PARTS
配件

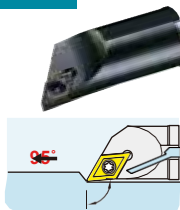
Page	Index	ØD	Insert	
			Item code	Shape
P.001	 	20	CN..1204	
		25		
		32		
		40		
		50		
P.002	 	20	CN..1204	
		25		
		32		
		40		
		50		
P.003	 	32	DN..150 4 DN..150 6	
		40		
P.004	 	20	TN..1604	
		25		
		32		
P.005	 	20	TN..1604	
		25		
		32		
		40		
		50		
P.006	 	20	TN..1604	
		25		
		32		
P.007	 	40	VN..1604	
		50		
P.008	 	20	WN..0804	
		25		
		32		
		40		

Page	Index	ØD	Insert	
			Item code	Shape
P.001	 	20	CN..1204	
		25		
		32		
P.002	 	25	SN..1204	
		32		
		40		
		50		
		60		
P.003	 	25	DN..150 4 DN..150 6	
		32		
P.004	 	20	TN..1604	
		25		
		32		
P.005	 	32	TN..1604	
		40		
		50		
		60		
P.007	 	25	VN..1604	
		32		
		40		
		50		
P.008	 	20	WN..0804	
		25		
		32		
		40		
		50		
P.008	 	20	WN..0804	
		25		
		32		
		40		

內徑車刀 BORING BARS

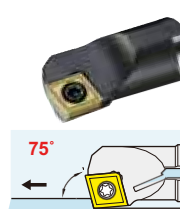
Page	Index	ØD	Insert	
			Item code	Shape
P.009	<p>SCLC</p>  <p>95°</p>	8	CC..0602	
		10		
		12		
		14		
		16		
		12		
		14		
		15		
		16		
		18		
		20		
		22		
		25		
32				
32				
40				
P.011	<p>SCLP</p>  <p>95°</p>	8	CP..0602	
		10		
		12		
		10		
		12		
		16		
		20		
25				
P.013	<p>SCLC/P</p>  <p>95°</p>	1004	CC..03S1	
		1005		
		1204		
		1206		
		1607		
		1608		
		1609		
		1612		
		2014		
		2016		
P.015	<p>SCNC/P</p>  <p>50°</p>	12	CC..0602	
		16	CP..0903	
P.016	<p>SDJC</p>  <p>95°</p>	8	DC..0702	
		10		
		12		
		16		
		1608		
		16		
		20		
		25		
32				

Page	Index	ØD	Insert	
			Item code	Shape
P.010	<p>SCLC.. Carbide shank</p>  <p>95°</p>	4	CC..03S1	
		5		
		6		
		7		
		8		
		10		
		12		
		14		
		16		
		12		
		14		
		16		
		20		
25				
P.012	<p>SCLP.. Carbide shank</p>  <p>95°</p>	10	CP..0802	
		12		
		12		
		16		
		25		
P.014	<p>SCKC/P</p>  <p>75°</p>	8	CC..0602	
		10		
		12		
		16		
		12		
		16		
		20		
		16		
P.015	<p>SCZC</p>  <p>93°</p>	8	CC..0602	
		10		
		12		
		16		
		20		
		40		

內徑車刀
BORING BARS

外徑車刀
TOOL HOLDERS

牙刀
THREADING & GROOVING









銑刀
MILLING







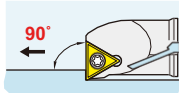

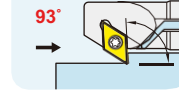

孔加工
BORING TOOLS COMPONENTS

配件
SPARE PARTS

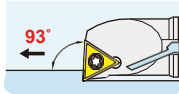

內徑車刀 BORING BARS



BORING BARS 內徑車刀
 TOOL HOLDERS 外徑車刀
 THREADING & GROOVING 牙刀 & 開槽刀
 MILLING 銑刀
 BORING TOOLS COMPONENTS 孔加工
 SPARE PARTS 配件

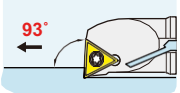

Page	Index	ØD	Insert	
			Item code	Shape
P.017	 	12	DC..0702	
		16		
		20	DC..11T3	
		25		
		32		
P.018	 	10	DC..0702	
		12		
		16		
		20	DC..11T3	
		16		
		20		
		25		
		32		
		40		
50				
P.020	 	6	TC..0601	
		8	TC..0902	
		8		
		10		
		10	TC..1102	
		12		
		16	TC..16T3	
		16		
		20		
25	TP..1603			
32				
16				



Page	Index	ØD	Insert	
			Item code	Shape
P.017	 	10	DC..0702	
		12		
		16		
		20	DC..11T3	
		25		
32				
P.019	 	10	DC..0702	
		12		
		16		
		20	DC..11T3	
		16		
		20		
		25		
		32		
		40		
P.021	 	6	TB..0601	
		8	TC..0902	
		8		
		10		
		12	TC..1102	
		14		
		10	TC..16T3	
		12		
		16		
		20	TC..16T3	
25				
32				
P.022	 	6	TB..0601	
		7		
		8		
		8	TC..0902	
		10		
		12	TC..1102	
		14		
		10		
		12	TC..1102	
16				

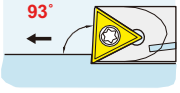

內徑車刀 **BORING BARS**

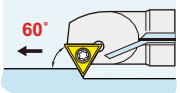

Page	Index	ØD	Insert	
			Item code	Shape
P.023	STUP  	8	TP..0802	
		10		
		12		
		16	TP..0902	
		8		
		10		
		10	TP..1103	
		12		
		14		
		15		
		16		
		18		
		20		
		22		
23				
25				
20	TP..1603			
25	TP..16T3			
32	TP..1604			

Page	Index	ØD	Insert		
			Item code	Shape	
P.024	STUP.. Carbide shank  	8	TP..0802		
		10			
		12			
		8	TP..0902		
		10			
		10			
		10	TP..1103		
		12			
		14			
		16			
		20			
		25			
		20			TP..16T3
		20			TP..1604

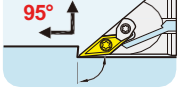
Page	Index	ØD	Insert	
			Item code	Shape
P.025	STUB/C  	0806	TB..0601	
		0807		
		1207		
		1206	TC..0601	
		1207		

Page	Index	ØD	Insert	
			Item code	Shape
P.026	STWC  	0806	TB..0601	
		8	TC..0902	
		10	TC..1102	
		12		
		14		
		16		
		20		
		20	TC..16T3	
		20		
		25		
32				

Page	Index	ØD	Insert	
			Item code	Shape
P.027	SVJB/C..CL  	16	VB/VC..1103	
		20		
		20	VB/VC..1604	
		25		
		32		
40				

Page	Index	ØD	Insert	
			Item code	Shape
P.026	STWP  	8	TP..0802	
		8	TP..0902	
		10	TP..1103	
		10		
		12		
		14		
		16		
		20	TP..1603	
		20		

內徑車刀
BORING BARS

外徑車刀
TOOL HOLDERS

牙刀
開槽刀
THREADING & GROOVING











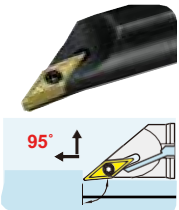
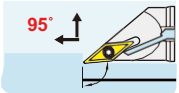

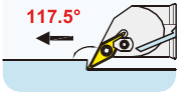
銑刀
MILLING







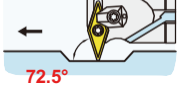

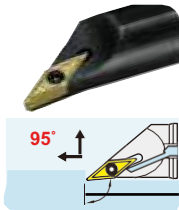

孔加工
BORING TOOLS COMPONENTS

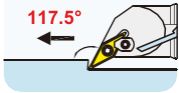
配件
SPARE PARTS

內徑車刀 BORING BARS

BORING BARS 內徑車刀
 TOOL HOLDERS 外徑車刀
 THREADING & GROOVING 牙刀 & 開槽刀
 MILLING 銑刀
 BORING TOOLS COMPONENTS 孔加工
 SPARE PARTS 配件

Page	Index	ØD	Insert	
			Item code	Shape
P.028	 	8	VC..0802	
		10		
		10		
		12	VB..110 3	
		16	VC..110 3	
		20	VB..160 4 VC..160 4	
		16		
		20		
		25		
		32		
40				
40				
P.030	 	20	VB..110 3 VC..110 3	
		25		
		32		
		40	VB..160 4 VC..160 4	
		20		
		25		
		32		
		40		
P.031	 	12	VB..110 3	
		16		
		20	VC..110 3	
		20	VB..160 4 VC..160 4	
		25		
		32		
		40		
40				
P.033	 	16	VB..110 3 VC..110 3	
		20		
		20	VB..1604	
		25		
		40		
		20		
		25		
		32		
40				
P.035	 	16	VB..110 3 VC..110 3	
		20		
		25	VB..160 4 VC..160 4	
		32		
		32		

Page	Index	ØD	Insert	
			Item code	Shape
P.029	 	8	VC..0802	
		10		
		10		
		12	VB..110 3	
		16	VC..110 3	
		20	VB..160 4 VC..160 4	
		16		
20				
25				
P.030	 	20	VB..160 4 VC..160 4	
		25		
		25		
P.032	 	12	VB..110 3	
		16		
		20	VC..110 3	
		20	VB..160 4 VC..160 4	
		25		
25				
P.034	 	12	VC..0802	
		1612		
		16	VB..110 3 VC..110 3	
		20		
		25		
		32	VB..160 4 VC..160 4	
		40		
P.035	 	25	VB..160 4 VC..160 4	
		32		

內徑車刀 **BORING BARS**

Page	Index	ØD	Insert	
			Item code	Shape
P.036	SVXC	25	VC..2205	
P.037	SWLC	0805	WC..0201	
		1005		
		1006		

Page	Index	ØD	Insert	
			Item code	Shape
P.036	SVXC	25	VC..2205	
P.037	SWUB	1005	WB..0601	
		1006		
		1007		
		1205		
		1605		

內徑車刀套筒 **SLEEVES FOR BORING BARS**

Page	Index	ØD	Ød
P.039 P.040	NC	16	03-12
		20	04-16
		25	04-22
		32	04-25
		40	05-32
		50	08-40
P.042	SHB	60	20-50
		16	02-10
		19.5	04-06
		20	02-10
		22	03-16
		22..PT02	03-12
		25	03-20
25.4	06-16		
P.040	NC...MTA	25	MTA1-MTA3
		32	MTA1-MTA3
		40	MTA1-MTA4
		50	MTA1-MTA5

Page	Index	H	ØD
P.044	SBHA	16	32
		20	32
		20	40
		25	32
		25	40
P.044	CH	20	5
			6
			8
			10
		25	5
			6
			8
10			

內徑車刀
BORING BARS

外徑車刀
TOOL HOLDERS

牙刀 & 開槽刀
THREADING & GROOVING









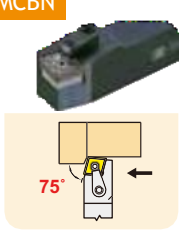

銑刀
MILLING

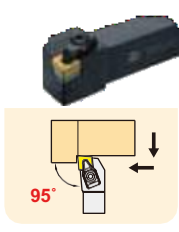
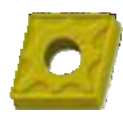
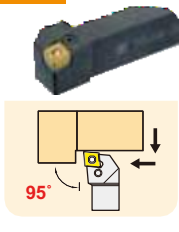



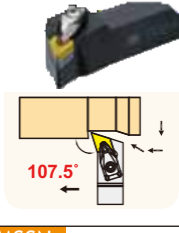

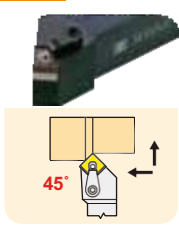

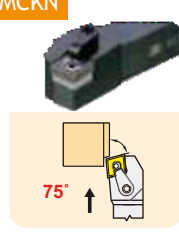

孔加工
BORING TOOLS COMPONENTS

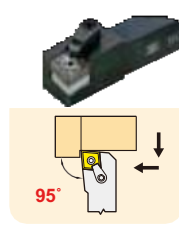
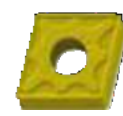
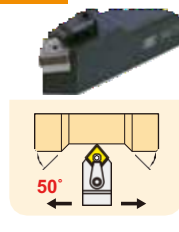
配件
SPARE PARTS

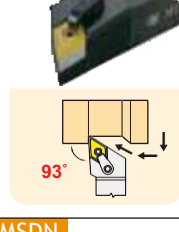
外徑車刀 TOOLHOLDERS

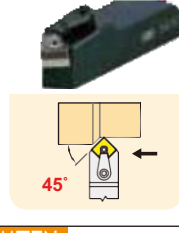









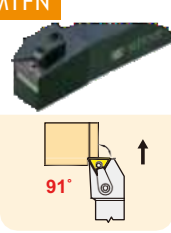

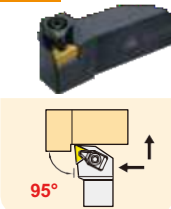
內徑車刀
BORING BARS
外徑車刀
TOOLHOLDERS
牙刀及開槽刀
THREADING & GROOVING
銑刀
MILLING
孔加工
BORING TOOLS COMPONENTS
配件
SPARE PARTS

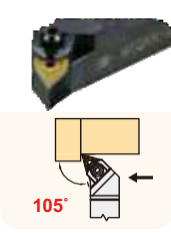
Page	Index	Height X Width	Insert	
			Item code	Shape
P.046		16×16	CN..1204	
		20×20		
		25×25		
		32×32		
P.047		16×16	CN..1204	
		20×20		
		25×25		
		32×32		
P.048		20×20	CN..1204	
		25×25		
		32×32		
P.049		20×20	DN..150 4 DN..150 6	
		25×25		
		32×32		
P.050		20×20	DN..150 4 DN..150 6	
		25×25		
		32×32		
P.051		16×16	SN..1204	
		20×20		
		25×25		

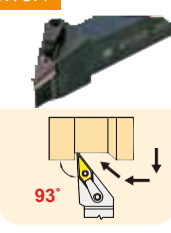
Page	Index	Height X Width	Insert	
			Item code	Shape
P.046		16×16	CN..1204	
		20×20		
		25×25		
		32×32		
P.047		16×16	CN..1204	
		20×20		
		25×25		
		32×32		
P.048		16×16	CN..1204	
		20×20		
		25×25		
		32×32		
P.049		20×20	DN..150 4 DN..150 6	
		25×25		
P.050		20×20	SN..1204	
		25×25		
P.051		12×16	TN..1604	
		16×16		
		20×20		
		25×25		

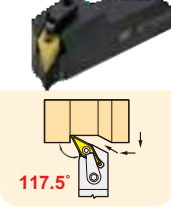
外徑車刀 TOOLHOLDERS

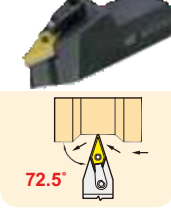
Page	Index	Height X Width	Insert	
			Item code	Shape
P.052	DTFN  91°	16×16	TN..1604	
		20×20		
		25×25		
		32×32		
P.053	PTFN  91°	20×20	TN..1604	
		25×25		
P.054	MTJN  93°	12×16	TN..1604	
		16×16		
		20×20		
		25×25		
P.055	DVJN  93°	20×20	VN..1604	
		25×25		
		32×32		
		32×32		
P.056	DVQN  117.5°	20×20	VN..1604	
		25×25		
		32×32		
P.057	DVVNN  72.5°	16×16	VN..1604	
		20×20		
		25×25		
		32×32		

Page	Index	Height X Width	Insert	
			Item code	Shape
P.052	MTFN  91°	16×16	TN..1604	
		20×20		
		25×25		
P.053	DTJN  95°	20×20	TN..1604	
		25×25		
		32×32		
P.054	MTQN  105°	20×20	TN..1604	
		25×25		
P.055	MVJN  93°	12×16	VN..1604	
		16×16		
		20×20		
		25×25		
		32×32		
P.056	MVQN  117.5°	20×20	VN..1604	
		25×25		
		32×32		
P.057	MVVNN  72.5°	16×16	VN..1604	
		20×20		
		25×25		

內徑車刀
BORING BARS

外徑車刀
TOOLHOLDERS

牙刀
開槽刀
THREADING & GROOVING

銑刀
MILLING

孔加工
BORING TOOLS COMPONENTS

配件
SPARE PARTS

外徑車刀 TOOLHOLDERS

內徑車刀 BORING BARS
外徑車刀 TOOLHOLDERS
牙刀及開槽刀 THREADING & GROOVING
銑刀 MILLING
孔加工 BORING TOOLS COMPONENTS
配件 SPARE PARTS

Page	Index	Height X Width	Insert	
			Item code	Shape
P.058		20×20	VN..1604	
		25×25		
		32×32		
P.059		20×20	WN..0804	
		25×25		
		32×32		
P.060		20×20	WN..0804	
		25×25		
		32×32		
P.061		16×16	CC..09T3	
		20×20		
		25×25		
P.062		10×10	CC..0602	
		12×12	CC..09T3	
		16×16		
		20×20		
		25×25	CC..1204	
		20×20		
25×25				
32×32				
P.063		16×16	CC..0602	
		12×12	CC..09T3	
		16×16		
		20×20		
		25×25	CC..1204	
		20×20		
25×25				

Page	Index	Height X Width	Insert	
			Item code	Shape
P.059		20×20	WN..0804	
		25×25		
P.060		16×20	WN..0804	
		20×20		
		25×25		
P.061		12×12	CC..09T3	
		16×16		
		20×20		
		25×25		
P.062		08×08	CC..0602	
		10×10	CC..09T3	
		12×12		
		16×16		
		20×20	CC..09T3	
25×25				
P.063		12×12	CP..0903	
		16×16		
		20×20		
		25×25		

外徑車刀 TOOLHOLDERS

Page	Index	Height X Width	Insert	
			Item code	Shape
P.064	<p>SDAC</p>	10×10	DC..070 2 DC..11T 3	
		12×12		
		16×16		
		20×20		
P.065	<p>SDJC</p>	10×10	DC..070 2 DC..11T 3	
		12×12		
		16×16		
		20×20	DC..11T3	
		25×25		
		32×32		
P.066	<p>SDNC</p>	10×10	DC..0702	
		12×12	DC..070 2	
		16×16	DC..11T 3	
		20×20	DC..11T3	
		25×25		
P.067	<p>SRAC</p>	10×10	RC..050 2 RC..060 2	
		12×12		
		16×16		
		20×20		
		25×25		
P.068	<p>SRDC</p>	10×10	RC..050 2 RC..060 2	
		12×12	RC..0502	
		16×16	RC..060	
		20×20	2	
		25×25	RC..080 3	
		32×32	RC..1003 RC..1003	
P.069	<p>SSAC</p>	9.5×12.7	SC..09T3	
		12.7×12.7		
		12×12		
		16×16		

Page	Index	Height X Width	Insert		
			Item code	Shape	
P.064	<p>SDFC</p>	12×12	DC..0702		
		12×12	DC..11T3		
		16×16			
P.065	<p>SDJ2C</p>	08×08	DC..0702		
		10×10	DC..070 2 DC..11T 3		
		12×12			
		16×16			
		20×20			
		25×25			
		32×32	DC..11T3		
P.066	<p>SDQC</p>	12×12	DC..11T3		
		16×16			
		20×20			
		25×25			
P.067	<p>SRAC</p>	12×12	RC..080 3 RC..100 3		
		16×16			
		20×20			
		25×25			
P.068	<p>SRGC</p>	12×12	RC..0602		
		16×16			
		20×20			
		25×25			
		16×16			RC..0803
		20×20			
P.069	<p>SSBC</p>	9.5×12.7	SC..09T3		
		12.7×12.7			
		12×12			

內徑車刀
BORING BARS

外徑車刀
TOOLHOLDERS

牙刀與開槽刀
THREADING & GROOVING











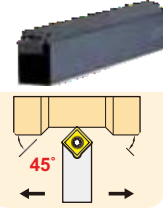

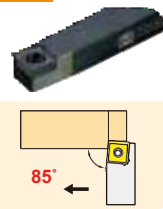
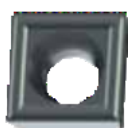
銑刀
MILLING

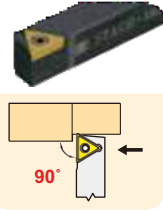

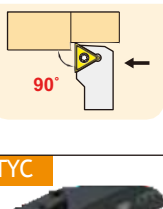

孔加工
BORING TOOLS COMPONENTS

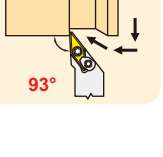
配件
SPARE PARTS

外徑車刀 TOOLHOLDERS

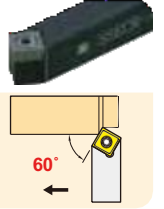
內徑車刀
BORING BARS
外徑車刀
TOOLHOLDERS
牙刀及開槽刀
THREADING & GROOVING
銑刀
MILLING
孔加工
BORING TOOLS COMPONENTS
配件
SPARE PARTS

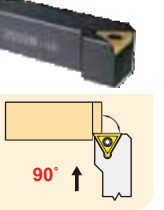
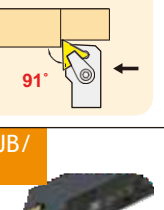
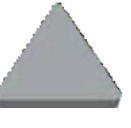
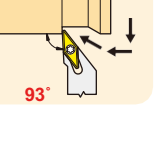
Page	Index	Height X Width	Insert		
			Item code	Shape	
P.070	SSDC 	9.5×12.7	SC..09T3		
		12.7×12.7			
		12×12			
		16×16			
		20×20			
P.071	SSXC 	9.5×12.7	SC..09T3		
		10×10	TC..1102		
		12×12			
		16×16			
		9.5×12.7			
12.7×12.7					
P.072	STAC 	12.7×16	TC..16T3		
		16×16			
		12×12	TC..16T3		
		16×16			
		19×19			
P.073	STGC/P 	20×20	TC..16T3		
		25×25	TC..16T3		
		25×25	TP..1603		
P.074	CTYC 	20×20	TC..16T3		
		25×25	TP..1603		
P.075	SVJB/C..CL 	10×10	VB..1103		
		12×12			
		16×16			
		20×20			
		25×25	VC..1103		
		16×16			
		20×20			
		25×25			
32×32	VB..1604				
32×32	VC..1604				

Page	Index	Height X Width	Insert	
			Item code	Shape
P.070	SSEC 	9.5×12.7	SC..09T3	
		12.7×12.7		
		12×12		
P.072	STFC 	20×20	TC..16T3	
		25×25		
		25×25		
P.074	CTGP 	16×16	TP.N1603	
		20×20		
		25×25		
P.075	SVJB/C 	10×10	VB..1103	
		12×12		
		16×16		
		20×20		
		25×25	VC..1103	
		16×16		
		20×20		
		25×25		
32×32	VB..1604			
32×32	VC..1604			

外徑車刀 TOOLHOLDERS

Page	Index	Height X Width	Insert	
			Item code	Shape
P.076	<p>93°</p>	10×10	VC..1103	
		12×12		
		16×16		
		20×20		
P.077	<p>117.5°</p>	12×12	VB..1103	
		16×16		
		20×20	VC..1103	
		20×20	VB..1604	
		25×25		
		32×32		
P.078	<p>95°</p>	20×20		VC..1604
		25×25		
P.078	<p>72.5°</p>	16×16	VC..1604	
		20×20		
		25×25		
		P.079		
12×12				
16×16				
20×20				
25×25	VC..1103			
16×16	VB..1604			
20×20				
25×25				
32×32		VC..1604		
P.080	<p>91°</p>	12×12	VC..1103	
		16×16		
		20×20		
		25×25		

Page	Index	Height X Width	Insert	
			Item code	Shape
P.076	<p>93°</p>	10×10	VB..1103	
		12×12		
		16×16		
		20×20	VC..1103	
		16×16	VC..1604	
		20×20		
25×25				
P.077	<p>117.5°</p>	12×12	VB..1103	
		16×16		
		20×20		
		20×20		
25×25				
P.078	<p>95°</p>	20×20	VC..1604	
		25×25		
P.078	<p>72.5°</p>	9.5×9.5	VC..1103	
		12.7×12.7		
		16×16		
		20×20		
		16×16	VC..1604	
		20×20		
25×25				
P.079	<p>72.5°</p>	10×10	VB..1103	
		12×12		
		16×16		
		20×20		
		25×25	VC..1103	
		16×16	VB..1604	
		20×20		
		25×25		
32×32	VC..1604			
P.080		25-32M 外徑墊高輔助刀座		

內徑車刀
BORING BARS

外徑車刀
TOOLHOLDERS







牙車開槽刀
THREADING & GROOVING

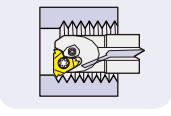

銑刀
MILLING

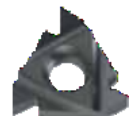
孔加工
BORING TOOLS COMPONENTS

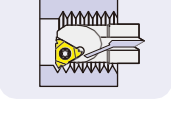

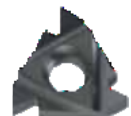
配件
SPARE PARTS

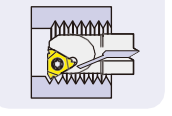
內徑牙刀 INTERNAL THREADING BORING BARS

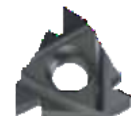
Page	Index	ØD	Insert	
			Item code	Shape
P.086	 	20	16NR/L	
		25		
		32		
		40		
		20	22NR/L	
		25		
32				
P.088	 	12	06NR/L	
		16	08NR/L 11NR/L	
		16	11NR/L	
		20		

Page	Index	ØD	Insert	
			Item code	Shape
P.087	 	8	08NR/L	
		10	11NR/L	
		12		
		16		
		20	16NR/L 22NR/L	
		25		
		32		
		40		

外徑牙刀 EXTERNAL THREADING TOOLHOLDERS

Page	Index	Height X Width	Insert	
			Item code	Shape
P.089	 	10X10	16ER/L	 
		12X12		
		12X16		
		16X16		
		20X20		
		25X25		
		32X32		
P.090	 	12X12	16ER/L	 
		16X16		
		20X20		
		25X25		
P.093	 	20X20	MTTR/L43..	
		25X25		
		32X32		

Page	Index	Height X Width	Insert	
			Item code	Shape
P.089	 	10X10	16ER/L	
		12X12		
		12X16		
		16X16		
		20X20		
		25X25	16ER/L 22ER/L	
		32X32		
		25X25		
		32X32		
P.093	 	16X16	MTTR/L43..	
		20X20		
		25X25		

外徑切槽刀 **EXTERNAL GROOVING TOOLHOLDERS**

Page	Index	Height X Width	Insert	
			Item code	Shape
P.095	WMTC 	10×10	WMTC015.. WMTC020..	
		12×12	WMTC015.. WMTC020.. WMTC094.. WMTC030..	
		16×16		
		20×20	WMTC020.. WMTC030..	
		25×25		
P.096	DGH 	16×16	DGM20CE	
		20×20		
		16×16	DGM30CT	
		20×20	DGM30CE	
		25×25	DGM40CT	
		32×32	DGJ40CE DGM50CT	
P.097	GYM 	20×20	GY2M03.. GY2M04.. GY2M05..	
		25×25		
		32×32		
P.099	GNDL 	16×16	GCMN30..	
		20×20	GCMN20.. GCMN30.. GCMN40..	
		25×25		
P.100	GNDM 	16×16	GCMN30..	
		20×20	GCMN30.. GCMN40..	
		25×25	GCMN30.. GCMN40.. GCMN50.. GCMN60..	
P.102	MGEH 	10×10	MGMN 150	
		12×12	MGMN 250	
		16×16	MGMN 200	
		20×20	MGMN 300	
		25×25	MRMN 200 MRMN 300	

Page	Index	Height X Width	Insert	
			Item code	Shape
P.095	WMTC..LH 	10×10	WMTC015.. WMTC020..	
		12×12	WMTC015.. WMTC020.. WMTC094.. WMTC030..	
		16×16	WMTC020.. WMTC094..	
P.097	GYM..LH 	10×10	GY2M02..	
		12×12		
		16×16		
P.99	GNDL..LH 	12×12	GCMN20.. GCMN30..	
		16×16	GCMN20..	
P.100	GNDM..LH 	12×12	GCMN30..	

內徑車刀
BORING BARS

外徑車刀
TOOLHOLDERS

牙車開槽刀
THREADING & GROOVING

銑刀
MILLING

孔加工
BORING TOOLS COMPONENTS

配件
SPARE PARTS





外徑切槽刀 EXTERNAL GROOVING TOOLHOLDERS



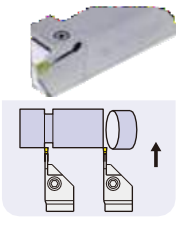

內徑車刀
BORING BARS
TOOLHOLDERS
外徑車刀
THREADING & GROOVING
牙刀 & 開槽刀
銑刀
MILLING
孔加工
BORING TOOLS COMPONENTS
配件
SPARE PARTS

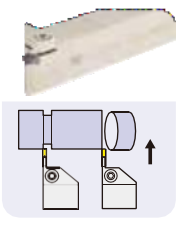
Page	Index	Height X Width	Insert	
			Item code	Shape
P.103	KGD 	10×10	GDM2020	
		12×12	GDM2020 GDM3020	
		16×16		
		20×20		
		25×25		
P.105	KGM 	12×12	GMM1520 GMM2020 GMM2520 GMM3020	
		16×16		
		20×20		
		25×25		
		20×20	GMM4020 GMM5020 GMM6020	
		25×25		
		32×32		
P.108	TTER/L 	20×20	TDC.. TSC.. TDJ.. TSJ.. TDT..	
		25×25		
P.109	DGT 	12×12	DGN20. DGN22. .	
		16×16	DGN20. DGN22. DGN30. DGN31. .	
		20×20		
		25×25		
P.111	GHD 	16×16		GIP.. GIF.. GIMF.. GIMY..
		20×20		
		25×25		
P.113	GFN 	12×12	GF□ 2	
		16×16	GF□ 2 GF□ 3	
		20×20		
		25×25		

Page	Index	Height X Width	Insert	
			Item code	Shape
P.103	KGD..LH 	10×10	GDM2020	
		12×12	GDM2020 GDM3020	
		16×16		
P.107	KTKH 	12×12		TKN 2 TKN 2.4
		16×16	TKN 2 TKN 2.4 TKN 3.1	
		20×20		
		25×25		
		25×25		TKN 4.1
		P.108	TTER/L..LH 	10×10
12×12				
16×16				
P.110	DGT..SH 	10×10	DGN20. DGN22. .	
		12×12		
		16×16		
P.112	GHG 	16×16	GIP.. GIF.. GIMF.. GIMY..	
		20×20		
		25×25		

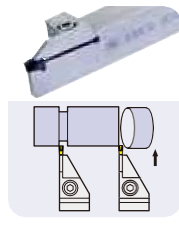
外徑切槽刀 **EXTERNAL GROOVING TOOLHOLDERS**

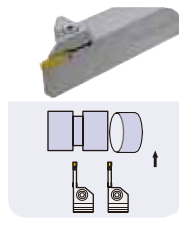
Page	Index	Height X Width		Insert	
		MIN	MAX	Item code	Shape
P.114	R/LF151.23 	16×16		N151.2-200.. N151.2-250.. N151.2-300..	
		20×20			
		25×25			
P.116	A3SM 	16×16		A2022..	
		20×20			
		25×25			

Page	Index	Height X Width		Insert	
		MIN	MAX	Item code	Shape
P.115	A3SC 	10×10		A2022..	
		12×12			
		16×16		A2022..	
		20×20		A2030..	
P.117	TNP 	16×16		TN300..	
		20×20			
		25×25			

內徑車刀
BORING BARS

外徑車刀
TOOLHOLDERS



牙刀 & 開槽刀
THREADING & GROOVING



銑刀
MILLING

孔加工
BORING TOOLS COMPONENTS

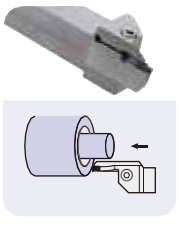

配件
SPARE PARTS

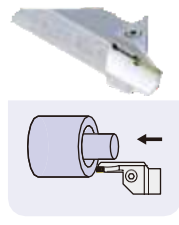

外徑端面開槽刀 **EXTERNAL FACE GROOVING TOOLHOLDERS**

Page	Index	Hole Diameter		Insert	
		MIN	MAX	Item code	Shape
P.118	KGDFR 	30	45	GDFM3020..	
		45	65		
		65	85		
		85	110		
		110	145		
		35	50	GDFM4020..	
		50	70		
		70	100		
		100	150	GDFM5020..	
		150	220		
		220	800		
		50	75		
		75	115		
	115	180			
	180	235			
	235	800			



Page	Index	Hole Diameter		Insert		
		MIN	MAX	Item code	Shape	
P.119	DGF 	28	34	DGM30CTF		
		34	45			
		45	70			
		70	100			
		100	140			
			140	200		DGM40CTF
			200	800		
			28	34		
			34	45		
			45	70		
P.120		70	100	DGM50CTF		
		100	140			
		140	200			
		200	800			
		50	70			
		70	120			
		120	240			
		240	800			

外徑端面開槽刀 *EXTERNAL FACE GROOVING TOOLHOLDERS*

Page	Index	Hole Diameter		Insert			
		MIN	MAX	Item code	Shape		
P.121		29	34	HFPR30..			
		34	40				
		40	48				
		48	60				
		60	75				
		75	100				
		100	140				
		140	200				
		200	800				
				29	34	HFPR40. GRIP40	
				34	40		
				40	48		
				48	60		
				60	75		
75	100						
100	140						
140	200						
200	800						

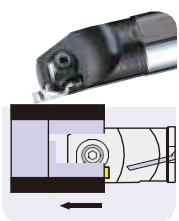

Page	Index	Height X Width	Adapter	
			Item code	Shape
P.122	HFAPR	20X25	HFAVR	
		25X25		
P.123	STCP	25X25	Insert	
			Item code	Shape
			TP..0902..	



內徑端面開槽刀 *INTERNAL FACE GROOVING TOOLHOLDERS*

Page	Index	ØD	Insert	
			Item code	Shape
P.124		16	GVFR..A	
		20		
		25		
		32		
			GVFR..B	

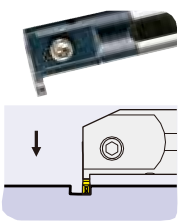
Page	Index	ØD	Insert	
			Item code	Shape

內徑開槽刀 *INTERNAL GROOVING TOOLHOLDERS*

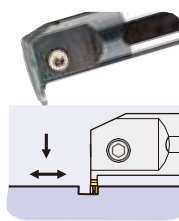
Page	Index	ØD	Insert	
			Item code	Shape
P.125		20	DGM30CT DGM40CT	
		25		
		32		
		32		
		40		
			DGM50CT	

Page	Index	ØD	Insert	
			Item code	Shape
P.126		16	GMM3014..	
		20		
		25		
		32		
		40		
			GMM4020. GDM4020..	

內徑車刀 BORING BARS
 外徑車刀 TOOLHOLDERS
 牙刀及開槽刀 THREADING & GROOVING
 銑刀 MILLING
 孔加工 BORING TOOLS COMPONENTS
 配件 SPARE PARTS

內徑開槽刀 INTERNAL GROOVING TOOLHOLDERS

Page	Index	ØD	Insert	
			Item code	Shape
P.128		08	GER..A	
		10	GER..B	
		12	GER..C	
		16	GER..C	
		20	GER..D	
P.130		16	GVR..S	
			S	
			GVR..S	
			GVR..A	

Page	Index	ØD	Insert	
			Item code	Shape
P.129		8	GVR..SS	
		10	GVR..S	
		12	GVR..A	
		16	GVR..A	
		20	GVR..B	
		32	GVR..C	
P.132		8	MLG10..L	
		10	MLT1001L	
		12	MLG14..L	
		14	MLT1401L	
		20	MLG20..L	

切斷切槽刀板 PARTING & GROOVING TOOLHOLDERS

Page	Index	Height	Insert	
			Item code	Shape
P.133		26	WCF □ 3	
		32		
P.134		26	GF □ 2/2.4 GF □ 3	
		32		
P.135		26	N151.2-200..	
		32		

Page	Index	Height	Insert	
			Item code	Shape
P.133		26	TK □ 3 TK □ 4	
		32		
P.134		26	GT □ 2/2.4 GT □ 3 GT □ 4	
		32		
P.135		26	FX3.1 FX4.1	
		32		

內徑車刀
BORING BARS

外徑車刀
TOOLHOLDERS

牙刀與開槽刀
THREADING & GROOVING

銑刀
MILLING

孔加工
BORING TOOLS COMPONENTS

配件
SPARE PARTS

切斷板座 TOOLBLOCK

Page	Index	Height	Blade	
P.136		16	SGIH26..	SGIH32..
		20	SGFH26..	SGFH32..
		25	KTKB26..	KTKB32..
			XLCFN26..	XLCFN32..
		19.05	STFH26..	STFH32..
		25.4	NF151.2-26..	NF151.2-32..

Page	Index	Height	Blade
P.136		25	SGIH26..
			SGFH26..
			KTKB26..
			XLCFN26..
			STFH26..
			NF151.2-26..











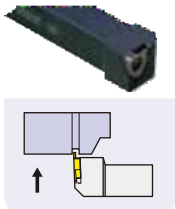

外徑切槽刀 EXTERNAL GROOVING TOOLHOLDERS

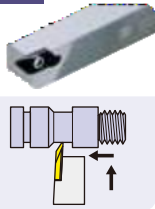
Page	Index	Height X Width	Insert	
			Item code	Shape
P.137		10×10	GTBT.. GTCT..	
		12×12		
		16×16		
		20×20		
P.138		12×12	SMGTR16X2.. SMGTR16X2..C SMTTR1603 60..	
		16×16		
		20×20		
		25×25		
P.140		20×20	MGTR/L33..	
		25×25		
		16×16	MGTR/L43..	
		20×20		
		25×25		
P.143		10×10	TGF32R/L	
		10×12		
		12×12		
		16×16		
		20×20		

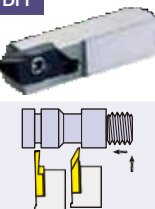
Page	Index	Height X Width	Insert	
			Item code	Shape
P.138		12×12	SMGTR16X2.. SMGTR16X2..C SMTTR1603 60..	
		16×16		
		20×20		
P.139		16×16	SMGTR16X2.. SMGTR16X2..C SMTTR1603 60..	
		20×20		
P.141		16×16	MGTR/L33.. MGTR/L43.. .	
		20×20		
		25×25		
		32×32		
P.143		16×16	TGF32R/L	
		20×20		
		25×25		

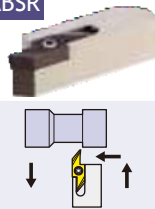
內徑車刀
BORING BARS
TOOLHOLDERS
外徑車刀
TOOLHOLDERS
牙刀及開槽刀
THREADING & GROOVING
銑刀
MILLING
孔加工
BORING TOOLS COMPONENTS
配件
SPARE PARTS

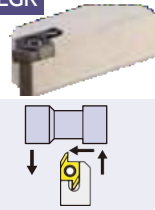
外徑切槽刀 **EXTERNAL GROOVING TOOLHOLDERS**

Page	Index	Height X Width	Insert	
			Item code	Shape
P.144	KTGFS 	16×16	TGF32R	
		20×20		
P.145 P.146 P.147	SAKGR 	10×10	AKBR3.. AKCR3.. AKPR3.. AKGR3.. AKTR3.. AKRR3..	
		12×12		
		16×16		
		20×20		
		25×25		
P.151	BTAH 	10×10	BTAT5528.. BTAT6035..	
		12×12		
		16×16		
P.153	CTBH 	10×10	BTBT60.. CTBT..	
		12×12		
		16×16		
		20×20		
P.155	SABSR 	10×10	ABS15R	
		12×12		
		16×16		
P.156	JSEGR 	10×10	J10ER..B..	
		12×12		

Page	Index	Height X Width	Insert	
			Item code	Shape
P.144	KTGFL 	Ø16	TGF32R	
P.148 P.149 P.150	SDKG 	10×10	DKCR/L3.. DKPR/L3.. DKBR/L4.. DKGR/L4.. DKTR/L4.. DKRR/L4..	
		12×12		
		16×16		
		20×20		
		25×25		
P.152	CTAHR 	10×10	CTAT	
		12×12		
		16×16		
		20×20		
P.154	KTKF 	10×10	TKF12R/L TKF16R/L	
		12×12		
		16×16		
		20×20	TKF16R/L	
		25×25		
P.155	SABWR 	08×10	ABW15R ABW23R	
		10×10		
		12×12		
		16×16		
		25×25		
P.157	SMALR 	10×10	MAGR3..	
		12×12		
		16×16		
		20×20		

內徑車刀
BORING BARS

外徑車刀
TOOLHOLDERS

牙刀及開槽刀
THREADING & GROOVING







銑刀
MILLING







孔加工
BORING TOOLS COMPONENTS

配件
SPARE PARTS

45° 面銑刀 45° FACEMILLING CUTTERS





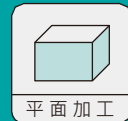

Page	Index	Cutter Dia	Insert	
			Item code	Shape
P.159	SNF 	Ø50-Ø160	SN..1205	
	ASX445 			
P.161 P.162		Ø50-Ø260	SE..13T3 R245-12T3	
P.164	TFM 	Ø50-Ø160	OFMT05T3..	

Page	Index	Cutter Dia	Insert	
			Item code	Shape
P.160	NFK 	Ø50-Ø160	OD..0605	
	MOF 			
P.163		Ø50-Ø125	OFMT0504..	

直角端銑刀 SHOULDER/CUTTING END MILLS



Page	Index	Cutter Dia	Insert	
			Item code	Shape
P.166	ASX400 	Ø50-Ø125	SO..12T3 WO..12T 3	
				
P.167 P.168	APM shank 	Ø12-Ø35	AOMT1236..	

Page	Index	Cutter Dia	Insert	
			Item code	Shape
P.169	APM modular 	Ø16-Ø35	AOMT1236..	
	APM shell 			
P.170		Ø50-Ø80	AOMT1236. . AOMT1848.	

內徑車刀
BORING BARS

外徑車刀
TOOL HOLDERS

牙刀 & 開槽刀
THREADING & GROOVING

銑刀
MILLING

孔加工
BORING TOOLS COMPONENTS

配件
SPARE PARTS

直角端銑刀 SHOULDER/CUTTING END MILLS



Page	Index	Cutter Dia	Insert		
			Item code	Shape	
P.171 P.172	BAP shank		Ø16-Ø32	APMT1135..	
				Ø25-Ø35	
P.175	BXD shank		Ø25-Ø32	XDGT1550..	
P.176	ASPV modular		Ø16-Ø35	MPHW0603..	
P.177	ASM shank		Ø08-Ø25	JDMT0702..	
	ASM modular		Ø10-Ø25	JDMT0702..	
P.179	AHU shank		Ø16-Ø35	JDMT1003..R	
			Ø25-Ø35	JDMT1505..R	

Page	Index	Cutter Dia	Insert		
			Item code	Shape	
P.173	BAP modular		Ø11-Ø36	APMT1135..	
			Ø25-Ø35	APMT1604..	
P.174	BAP shell		Ø40-Ø80	APMT1135..	
			Ø40-Ø125	APMT1604..	
P.175	BXD shell		Ø50-Ø80	XDGT1550..	
P.176	ASV shell		Ø50-Ø80	MPHW1205	
P.178	ASM_R shank		Ø10-Ø17	EDMT070220 .. JDMT0702..	
	ASM_R modular			Ø10-Ø25	
P.180	AHU modular		Ø16-Ø35	JDMT1003..R	
			Ø25-Ø40	JDMT1505..R	
	AHU shell		Ø50-Ø80	JDMT1505..R	

內徑車刀 BORING BARS
外徑車刀 TOOL HOLDERS
牙車開槽刀 THREADING & GROOVING
銑刀 MILLING
孔加工 BORING TOOLS COMPONENTS
配件 SPARE PARTS

直角端銑刀 SHOULDER/CUTTING END MILLS

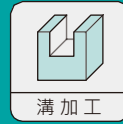

內徑車刀
BORING BARS
外徑車刀
TOOLHOLDERS
牙刀及開槽刀
THREADING & GROOVING
銑刀
MILLING
孔加工
BORING TOOLS COMPONENTS
配件
SPARE PARTS

Page	Index	Cutter Dia	Insert	
			Item code	Shape
P.181	HCP shank	Ø16-Ø33	CPMT0903..	
P.183	UEX shank	Ø12-Ø21	APET1202..	
		Ø25-Ø33	ADET1603..	
P.185	WEX shank	Ø12	AXMT0602..	
		Ø10-Ø33	AXMT1235..	
		Ø25-Ø33	AXMT1705..	
P.188	WEM shank	Ø15-Ø25	APMT1035..	
	WEM modular	Ø16-Ø26	APMT1035..	

Page	Index	Cutter Dia	Insert	
			Item code	Shape
P.182	HCP shell	Ø50-Ø63	CPMT0903..	
		Ø50-Ø80	CPMT1204..	
	AJC modular			
		Ø16-Ø26	CCMT0602..	
P.184	UEX modular	Ø16-Ø33	APET1202..	
		Ø25-Ø33	ADET1603..	
	UEX shell			
		Ø40-Ø100	ADET1603..	
P.186	WEX modular	Ø10-Ø33	AXMT1235..	
		Ø26-Ø33	AXMT1705..	
P.187	WEX shell	Ø50-Ø80	AXMT1235..	
		Ø40	AXMT1705..	
P.189	MEA shank	Ø12-Ø26	NDK.0903..	

直角端銑刀 SHOULDER/CUTTING END MILLS



Page	Index	Cutter Dia	Insert	
			Item code	Shape
P.190	MEC shank	Ø10-Ø13	BDMT0703..	
		Ø16-Ø33	BDMT11T3..	
P.192	TE90A06 shank	Ø08-Ø17	AXMT0602..	
P.193	TE90A shank	Ø12-Ø35	APKT09T3..	
		Ø25-Ø32	APKT1705..	
P.195	AKS shank	Ø10-Ø17	XOMT0602	
		Ø16-Ø33	XOMT0903..	
		Ø16-Ø35	XOMT10T3..	
		Ø18-Ø28	XOMT1204..	
P.197		Ø16-Ø32	APKT1003..	
		Ø24-Ø35	APKT1604..	

Page	Index	Cutter Dia	Insert	
			Item code	Shape
P.191	MEC modular	Ø10-Ø13	BDMT0703..	
		Ø16-Ø33	BDMT11T3..	
P.192	MEC shell	Ø40-Ø63	BDMT11T3..	
P.192	TE90A06 modular	Ø09-Ø17	AXMT0602..	
P.194	TE90A modular	Ø16-Ø35	APKT09T3..	
		Ø26-Ø35	APKT1705..	
P.194	TE90A shell	Ø50-Ø80	APKT09T3..	
P.196	AKS modular	Ø10-Ø25	XOMT0602	
		Ø16-Ø33	XOMT0903..	
P.198	CAP modular	Ø16-Ø26	APKT1003..	
P.199	CAP shell	Ø50-Ø63	APKT1003..	
		Ø40-Ø100	APKT1604..	

內徑車刀
BORING BARS

外徑車刀
TOOL HOLDERS

牙刀及開槽刀
THREADING & GROOVING

銑刀
MILLING

孔加工
BORING TOOLS COMPONENTS

配件
SPARE PARTS

直角端銑刀 SHOULDER/CUTTING END MILLS

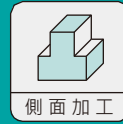

內徑車刀
BORING BARS
 外徑車刀
TOOLHOLDERS
 牙刀及開槽刀
THREADING & GROOVING
 銑刀
MILLING
 孔加工
BORING TOOLS COMPONENTS
 配件
SPARE PARTS

Page	Index	Cutter Dia	Insert	
			Item code	Shape
P.200	CAPW shell	Ø80-Ø100	APKT1604..	
P.201 P.202	VAX shank	Ø16-Ø35	R390-11T3	
			Ø25-Ø33	R390-1704
P.205	TPS17 shank	Ø25-Ø32	ASMT1705	

Page	Index	Cutter Dia	Insert	
			Item code	Shape
P.203	VAX modular	Ø16-Ø35	R390-11T3	
			Ø25-Ø33	
P.204	VAX shell	Ø50-Ø100	R390-11T3	
			Ø50-Ø80	
P.205	TPS17 shell	Ø63-Ø100	ASMT1705	

鑽銑刀

BORING & MILLING CUTTER



Page	Index	Cutter Dia	Insert		
			Item code	Item code	Shape
P.207	AQX shank	Ø16-Ø40	QO.T0830R. QO.T1035R. QO.T1342R.. QO.T1651R.. QO.T1856R.. QO.T2062R.	--	
P.209	AJU shank	Ø08-Ø11	CCMT060204..	--	
		Ø12-Ø13	CPMT080204Z	--	
		Ø16-Ø17	CPMT080204Z	CCMT060204..	
		Ø20-Ø21	CPMT090204Z	CCMT060204..	
		Ø25-Ø26	CPMT120308Z	CPMT090308..	
		Ø32-Ø33	CPMT160408Z	CPMT120408..	
P.211	ASJ shank	Ø20-Ø21	ADMT1003..L	ACMT1003..R	
		Ø25-Ø26	ADMT12T3..L	APMT12T3..R	
		Ø32-Ø33	APMT1604..L	APMT1504..R	
		Ø35	APMT1704..L	APMT1504..R	
P.213	ASJ shank (4 teeth)	Ø20-Ø21	ADMT1003..L	ACMT1003..R	
		Ø25-Ø26	ADMT12T3..L	APMT12T3..R	
		Ø32-Ø33	APMT1604..L	APMT1504..R	
		Ø35	APMT1704..L	APMT1504..R	
P.215 P.216	RT shank	Ø06-Ø21	RT0702..	--	
		Ø16-Ø35	RT1003..	--	

Page	Index	Cutter Dia	Insert		
			Item code	Item code	Shape
P.208	AQX modular	Ø16-Ø33	QO.T0830R.. QO.T1035R.. QO.T1342R.. QO.T1651R..	--	
P.210	AJU modular	Ø16-Ø17	CPMT080204Z	CCMT060204..	
		Ø20-Ø21	CPMT090204Z	CCMT060204..	
		Ø25-Ø26	CPMT120308Z	CPMT090308..	
		Ø32-Ø33	CPMT160408Z	CPMT120408..	
P.212	ASJ modular	Ø20-Ø21	ADMT1003..L	ACMT1003..R	
		Ø25-Ø26	ADMT12T3..L	APMT12T3..R	
		Ø32-Ø33	APMT1604..L	APMT1504..R	
		Ø35	APMT1704..L	APMT1504..R	
P.214	PG shank	Ø20-Ø21	PG100308..	--	
		Ø25-Ø26	PG130408..	--	
		Ø32-Ø33	PG160408..	--	
P.217	RT modular	Ø09-Ø21	RT0702..	--	
		Ø16-Ø35	RT1003..	--	
P.218	RT shell	Ø50-Ø66	RT1003..	--	

內徑車刀
BORING BARS

外徑車刀
TOOL HOLDERS

牙刀 & 開槽刀
THREADING & GROOVING

銑刀
MILLING



孔加工
BORING TOOLS COMPONENTS



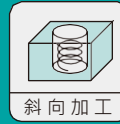

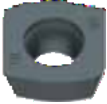

配件
SPARE PARTS

高進給銑刀 HIGH FEED MILLS



內徑車刀
 BORING BARS
 外徑車刀
 TOOL HOLDERS
 牙刀 & 開槽刀
 THREADING & GROOVING
 銑刀
 MILLING
 孔加工
 BORING TOOLS COMPONENTS
 配件
 SPARE PARTS

Page	Index	Cutter Dia	Insert	
			Item code	Shape
P.219	AJX shank	Ø20-Ø22	JO..06T2	
		Ø20-Ø35	JO..0803	
		Ø32-Ø40	JD..1204 WD..120 4	
	AJX modular	Ø16-Ø35	JO..0803	
P.221	ASR shank	Ø20	EPNW0803..	
		Ø25-Ø35	EDNW10T3..	
		Ø32-Ø35	EDNW13T4....	
	ASR modular	Ø20	EPNW0803..	
		Ø25	EDNW10T3..	
		Ø35	EDNW13T4	
P.223	ASRS shank	Ø16-Ø35	EPMT0603..	
				
	ASRS modular	Ø16-Ø35	EPMT0603..	
				

Page	Index	Cutter Dia	Insert	
			Item code	Shape
P.220	AJX shell	Ø50-Ø80	JD..1204 WD..120 4	
		Ø63-Ø100	JD..1405 WD..140 5	
P.222	ASR shell	Ø50-Ø80	EDNW13T4..	
		Ø63-Ø100	EDNW15T4..	
P.224	ASRS..C modular	Ø25-Ø35	EPMT0603..	
		Ø52	EPMT0603..	
	ASR shell	Ø52	EPMT0603..	
				

高進給銑刀
HIGH FEED MILLS



Page	Index	Cutter Dia	Insert	
			Item code	Shape
P.225	ASS shank 	Ø20-Ø35	SP..07T2	
	AJX modular 			
P.228	ASRF4 modular 	Ø32-Ø42	SD..1205	
P.229	EXN shank 	Ø15-Ø35	LNMU03..	
	TEBL shank 			
P.231		Ø16-Ø35	BLMP0603..	

Page	Index	Cutter Dia	Insert	
			Item code	Shape
P.226	ASS shell 	Ø50-Ø63	SP..07T2	
	ASRF4 shell 			
P.228		Ø42-Ø80	SD..1205	
P.230	EXN modular 	Ø16-Ø42	LNMU03..	
	EXN shell 			
P.232	TEBL modular 	Ø16-Ø42	BLMP0603..	
	TEBL shell 			
P.232		Ø50	BLMP0603..	

內徑車刀
BORING BARS

外徑車刀
TOOLHOLDERS

牙刀
開槽刀
THREADING & GROOVING

銑刀
MILLING

孔加工
BORING TOOLS COMPONENTS

配件
SPARE PARTS

圓刃銑刀 CORNER ROUNDING END MILLS



內徑車刀
BORING BARS
外徑車刀
TOOLHOLDERS
牙刀及開槽刀
THREADING & GROOVING
銑刀
MILLING
孔加工
BORING TOOLS COMPONENTS
配件
SPARE PARTS

Page	Index	Cutter Dia	Insert	
			Item code	Shape
P.233	BRP/RP shank 	Ø20	RP..08T2	
		Ø25-Ø26	RP..10T3	
		Ø25-Ø40	RP..1204	
		Ø20-Ø26	RP..1003	
P.234	RPM shell 	Ø50-Ø100	RP..1204	
P.235 P.236	HAR shank 	Ø10-Ø13	RD..0501	
		Ø12-Ø26	RD..0802	
		Ø25-Ø40	RD..10T3	
		Ø25	RD..1204	
P.239 P.240	HAR shell 	Ø40-Ø86	RD..10T3	
		Ø40-Ø80	RD..1204	
		Ø50-Ø160	RD..1604	
P.243	RD modular 	Ø09-Ø17	RD..0501	
		Ø15-Ø35	RD..0702	
		Ø20-Ø42	RD..1003	
P.245	TR shank 	Ø20-Ø35	RD..1003	
	TR modular 	Ø20-Ø35	RD..1003	

Page	Index	Cutter Dia	Insert	
			Item code	Shape
P.233	BRP/RP modular 	Ø25	RP..10T3	
		Ø25-Ø26	RP..1204	
		Ø20-Ø35	RP..1003	
P.237 P.238	HAR modular 	Ø10-Ø17	RD..0501	
		Ø16-Ø25	RD..0802	
		Ø20-Ø42	RD..10T3	
		Ø25-Ø42	RD..1204	
P.241 P.242	RD shank 	Ø09-Ø17	RD..0501	
		Ø15-Ø35	RD..0702	
		Ø20-Ø35	RD..1003	
P.244	RD shell 	Ø50-Ø80	RD..1003	
P.246	TR shell 	Ø50-Ø66	RD..1003	

球型銑刀 BALLENDMILLS

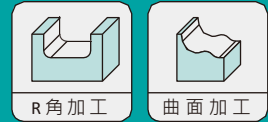

Page	Index	Cutter Dia	Insert	
			Item code	Shape
P.247	SE shank	Ø12-Ø20	QP..12090 3	
			QP..1612T3 QP..20150 4	

Page	Index	Cutter Dia	Insert	
			Item code	Shape
P.248	SR shank	Ø12-Ø25	ZP 1200.. ZP 1600.. ZP 2000.. ZP 2500..	
			SR modular	

球型銑刀 BALLENDMILLS

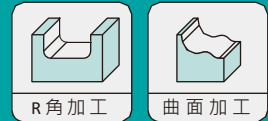

Page	Index	Cutter Dia	Insert	
			Item code	Shape
P.249	WGR shank	Ø8-Ø30	WGRMT-D08 WGRMT-D30	
P.251	PPH shank	Ø8-Ø25	PHB08.. PHB20.. .	
			BNM-080.. BNM-250.. .	
	PPH modular			

Page	Index	Cutter Dia	Insert	
			Item code	Shape
P.250	GWV shank	Ø12-Ø20	WPV 12.. WPV 20.. .	
			GWV modular	
P.252	PPHT shank	Ø12-Ø20	SUFT12R.. SUFT16R.. SUFT20R.. .	
			PPHT modular	
			RNM-120.. RNM-160.. RNM-200.. .	

內徑車刀
BORING BARS

外徑車刀
TOOL HOLDERS

牙刀
開槽刀
THREADING & GROOVING

銑刀
MILLING

孔加工
BORING TOOLS COMPONENTS

配件
SPARE PARTS

內徑車刀
 BORING BARS
 外徑車刀
 TOOL HOLDERS
 牙刀及開槽刀
 THREADING & GROOVING
 銑刀
 MILLING
 孔加工
 BORING TOOLS COMPONENTS
 配件
 SPARE PARTS

T型銑刀 T-SLOT END MILLING CUTTERS

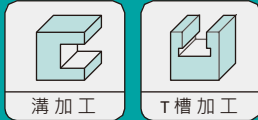

Page	Index	Cutter Dia	Insert	
			Item code	Shape
P.253	CCT shank	ø21-ø40	CCMT0602..	
		ø32-ø45	CCMT0803..	
		ø40-ø60	CCMT09T3..	
		ø50	CCMT1204..	
P.253	CCT shell	ø100-ø125	CCMT0602..	
		ø80	CCMT0803..	

DCWR銑刀 DCWR DOVETAIL CUTTER

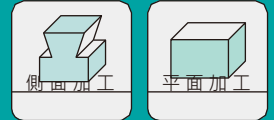

Page	Index	Cutter Dia	Insert	
			Item code	Shape
P.254	DCWR60° shank	ø16-ø30	DCMT0702..	
			ø40-ø60	
	DCWR75° shank	ø50	DCMT11T3..	
			DCMT11T3..	
P.254	DCWR modular	ø35	DCMT0702..	
			ø40	





倒角刀 CHAMFER MILLS



Page	Index	ØD	Insert	
			Item code	Shape
P.254	TCRM shank	ø21.5	TCMX16T308	
P.254	TCR shank	ø25	TC..16T3	

Page	Index	ØD	Insert	
			Item code	Shape
P.256	VMSP shank	ø22-ø35	SP..0903	
	VMSP modular	ø35	SP..0903	
P.256	TPR shank	ø4	TP..1603	

連接式刀桿 EXTENSION ADAPTER

Page	Index	ØD	M	
P.257 P.258	MD 	Ø12-Ø32	M5-M16	
	MD 	Ø16-Ø42	M6-M16	
	HD Carbide 	Ø12-Ø32	M4-M16	
	Arbor 	BT40		

內徑車刀
BORING BARS

外徑車刀
TOOL HOLDERS



牙刀及開槽刀
THREADING & GROOVING

銑刀
MILLING

孔加工
BORING TOOLS COMPONENTS

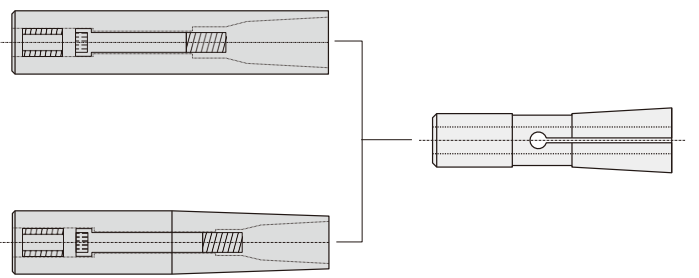

配件
SPARE PARTS



鎢鋼後拉式刀桿 CARBIDE HDC CHUCK & COLLET

Page	Index	ØD	Collet	
P.259	HDC/HUC chuck 	Ø8-Ø20	HDC 4 HDC 6 HUC 10	
	HDC/HUC chuck 	Ø12-Ø25	HDC 4 HDC 6 HUC 10	
	HDC/HUC collet 	Ø3-Ø10		

BORING BARS 內徑車刀
 TOOL HOLDERS 外徑車刀
 THREADING & GROOVING 牙刀及開槽刀
 MILLING 銑刀
 BORING TOOLS COMPONENTS 孔加工
 SPARE PARTS 配件

替換式快速鑽頭 INDEXABLE INSERTS HIGH SPEED DRILLS







Page	Index	ØD	Insert	
			Item code	Shape
P.261		18-40	WC..03020	
			8	
			WC..04020	
			8	
			WC..05030	
			8	

Page	Index	ØD	Insert	
			Item code	Shape
P.262		13-39	WD..04..	
			WD..05..	
			WD..06..	
			WD..07..	
			WD..09..	
			WD..12..	

固定式粗搪刀 FIXED ROUGH BORING BARS





Page	Index	ØD	Insert	
			Item code	Shape
P.263 P.264		8-57	CC..060204	
			CC..09T304	
P.267 P.268 P.269		45-201	CC..09T304	
			CC..120404	
P.270		70-100	CP..090308	

Page	Index	ØD	Insert	
			Item code	Shape
P.265 P.266		8-57	CC..060204	
			CC..09T304	
P.270		26-40	CP..090308	
P.270		13-25	CC..060204	

可調式粗搪刀 ADJUSTABLE ROUGH BORING BARS



Page	Index	Cutter Dia	Insert	
			Item code	Shape
P.271		175-425	CC..120404	

Page	Index	Cutter Dia	Insert	
			Item code	Shape

搪孔刀頭 & 配件
BORING HEAD & PART

Page	
	<p>EC1605 SC05H-SWUBR-06 Ø6 ~ Ø7.5</p>
	<p>EC1606 SC06J-SWUBR-06 Ø7 ~ Ø9</p>
	<p>EC1608 SC08-M5-115</p>
	<p>EC1610 SC10-M6-115</p>
	<p>EC1612 SC10-M6-135</p>
	<p>EC1614 SC10-M6-160</p>
	<p>SC12-M6-135</p>
	<p>SC12-M6-165</p>
	<p>SC14-M6-160</p>
	<p>SC16-M10-105</p>
	<p>SC16-M10-140</p>
	<p>SC16-M10-180</p>
	<p>BE09A, Ø9~Ø10.5</p>
	<p>BE10.5A, Ø10.5~Ø12</p>
	<p>BE12A, Ø12~Ø14</p>
	<p>BE14A, Ø14~Ø16</p>
	<p>BE16A, Ø16~Ø18</p>
	<p>BE18A, Ø18~Ø20</p>
	<p>BE20A, Ø20~Ø22</p>
	<p>BE22A, Ø22~Ø24</p>
	<p>BE24A, Ø24~Ø26</p>
	<p>BE26A, Ø26~Ø28</p>
	<p>BE28A, Ø28~Ø30</p>
	<p>BE30A, Ø30~Ø32</p>
	<p>BE32A, Ø32~Ø34</p>
	<p>BE34A, Ø34~Ø36</p>
	<p>BE36A, Ø36~Ø38</p>
	<p>BE38A, Ø38~Ø40</p>
	<p>BE40A, Ø40~Ø42</p>
	<p>BE42A, Ø42~Ø44</p>
	<p>BE44A, Ø44~Ø46</p>
	<p>BE46A, Ø46~Ø48</p>
	<p>BE48A, Ø48~Ø50</p>
	<p>BE50A, Ø50~Ø52</p>

P.273
P.274

- 內徑車刀
BORING BARS
- 外徑車刀
TOOL HOLDERS
- 牙刀
開槽刀
THREADING & GROOVING
- 銑刀
MILLING
- 孔加工
BORING TOOLS COMPONENTS
- 配件
SPARE PARTS

小徑搪刀 BORING SHANK

內徑車刀
BORING BARS

外徑車刀
TOOLHOLDERS

牙刀 & 開槽刀
THREADING & GROOVING







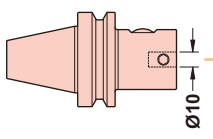
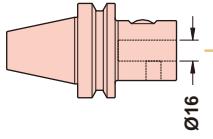
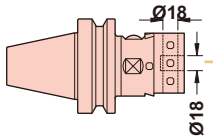
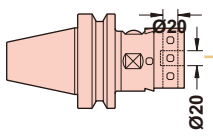

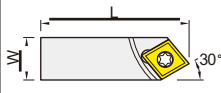

銑刀
MILLING





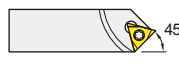

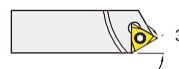

孔加工
BORING TOOLS COMPONENTS

配件
SPARE PARTS

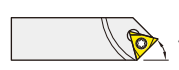
Page	
P.275 P.276 P.277 P.278	 <ul style="list-style-type: none"> BJ1008-32 BJ1010-40 BJ1012-45 BJ1016-45 BJ1020-45
	 <ul style="list-style-type: none"> BJ1608-16 BJ1610-20 BJ1612-24 BJ1616-32
	 <ul style="list-style-type: none"> BJ1808-32 BJ1810-40 BJ1812-53 BJ1816-68 BJ1820-83 BJ1825-90 BJ1830-90 BJ-L18-36
	 <ul style="list-style-type: none"> BJ2008-32 BJ2010-40 BJ2012-53 BJ2016-68 BJ2020-83 BJ2025-96 BJ2030-115 BJ-L20-36
	<ul style="list-style-type: none"> SB1608-32 SB1610-40 SB1612-53 SB1616-68 SB1620-83 SB1625-90 SB1630-90 SB1640-90
	<ul style="list-style-type: none"> SB1610-30 SB1612-35 SB1614-40 SB1615-45 SB1616-50 SB1618-55 SB1620-60 SB1622-65 SB1625-70

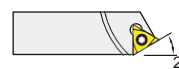
小徑搪刀
BORING SHANK

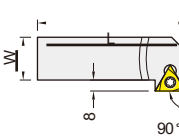
Page	Index	Height × Width	Insert			
			Item code	Shape		
P.279	TBS 	6×6	CC..0602			
		8×8				
		10×10				
		13×13	CC..09T3			
		16×16				
		19×19				
		19×19	CC..1204			
		25×25				
	SBS 	6×6	TP..0902			
		8×8				
		10×10				
			13×13			TP..1103
			16×16			
			16×16			
			16×16			TP..1603
			19×19			
			25×25			
TBSL 	6×6	CC..0602				
	8×8					
	10×10					
	13×13	CC..09T3				
	16×16					
	19×19					
25×25	CC..1204					

Page	Index	Height × Width	Insert		
			Item code	Shape	
P.257	TSBS 	6×6	TC..0902		
		8×8			
		10×10			
		13×13	TC..1102		
		16×16			
		19×19			
		19×19	TC..16T3		
		25×25			
	SBS.. A 	8×8	TP..0902		
		10×10			
		13×13	TP..1103		
16×16					
		19×19	TP..1603		
BSB 	16×16	TP..1103			
	20×20				
	25×25				

內徑車刀
BORING BARS

外徑車刀
TOOLHOLDERS

牙車開槽刀
THREADING & GROOVING

銑刀
MILLING

孔加工
BORING TOOLS COMPONENTS









配件
SPARE PARTS



內徑車刀
 BORING BARS
 外徑車刀
 TOOL HOLDERS
 牙刀及開槽刀
 THREADING & GROOVING
 銑刀
 MILLING
 孔加工
 BORING TOOLS COMPONENTS
 配件
 SPARE PARTS

卡式刀座 Cartridges

Page	Index	Height	Insert	
			Item code	Shape
P.280	SCFC 	08CA	CC..0602..	
		10CA	CC..09T3..	
		12CA	CC..1204..	
P.280	SSSPR 	10CA	SP..0903..	
P.280	STFPR 	08CA	TP..0902..	
		10CA	TP..1103..	
		12CA	TP..1603..	
P.281	STSPR 	08CA	TP..0902..	
		10CA	TP..1103..	
		12CA	TP..1603..	
P.281	STTCR 	08CA	TC..0902..	

Page	Index	Height	Insert	
			Item code	Shape
P.280	SRSCR 	10CA	RC..10T3..	
P.280	STFCR 	08CA	TC..0902..	
		10CA	TC..1102..	
		12CA	TC..16T3..	
P.281	STGCL 	12CA	TC..16T3..	
P.281	STSCR 	08CA	TC..0902..	
		10CA	TC..1102..	
		12CA	TC..16T3..	

內徑車刀
BORING BARS

外徑車刀
TOOLHOLDERS

牙刀及開槽刀
THREADING & GROOVING

銑刀
MILLING

孔加工
BORING TOOLS COMPONENTS

配件
SPARE PARTS

M	C	L	N	R	2	5	2	5	M	1	2	*
1	2	3	4	5	6	7	8	9	10	11	12	13

1 刀片挾持方式 TYPE OF LOCKING

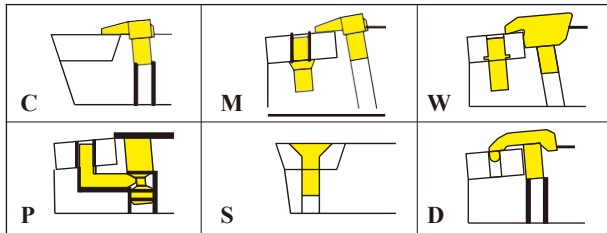

2 刀片形狀 INSERT SHAPE

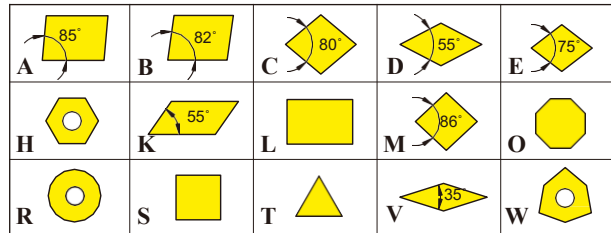

3 切入角 TYPE OF TOOL

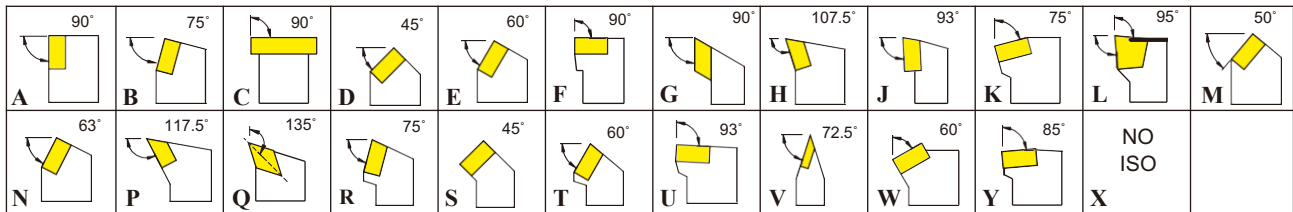

4 刀片逃隙角 RAKE ANGLES

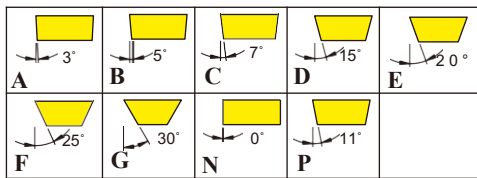

6/7 刀柄高度 SHANK HEIGHT

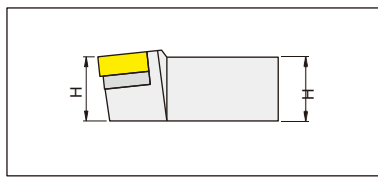

10 刀柄長度 TOOL LENGTH

	32	A B C D E F G H J K L M N P Q R S T U V W Y X
	40	
	50	
	60	
	70	
	80	
	90	
	100	
	110	
	125	
	140	
	150	
	160	
	170	
	180	
	200	
	250	
	300	
	350	
400		
450		
500		
SPECIAL		

5 方向 HAND OF TOOL

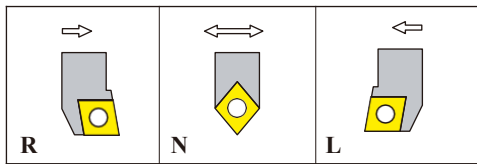

8/9 刀柄寬度 SHANK WIDTH

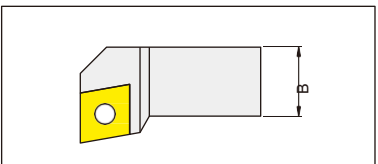

11/12 切刃長 CUTTING EDGE LENGTH

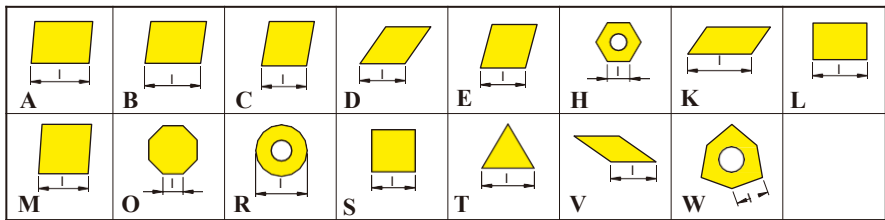

13 特殊註記 OPTIONAL CODE

INSERTS	R-L
---------	-----

TOOLS DESIGNATION: INTERNAL TURNING

S	2	0	R	S	C	L	C	R	0	9	*
6	8	9	10	1	2	3	4	5	11	12	13



6 刀柄 SHANK

S = 鋼柄 Steel shank
 A = 鋼柄+中心水孔 Steel shank+coolant hole
 B = 抗震鋼柄 Steel shank+device anti-vibration
 C = 鎢鋼柄 Cemented carbide shank with steel head
 D = 抗震鋼柄+中心水孔 Steel shank+device anti-vibration+coolant hole
 E = 鎢鋼柄+中心水孔 Cemented carbide shank with steel head+coolant hole
 F = 抗震鎢鋼柄 Cemented carbide shank with steel head+device anti-vibration
 G = 抗震鎢鋼柄+中心水孔 Cemented carbide shank with steel head+device anti-vibration+coolant hole
 H = 重金屬 Heavy metal shank
 J = 重金屬+中心水孔 Heavy metal shank+coolant hole

卡式刀座指定系統 CARTRIDGES DESIGNATION

S	T	F	C	R	1	0	C	A	1	1
1	2	3	4	5	6	7	8	9	11	12

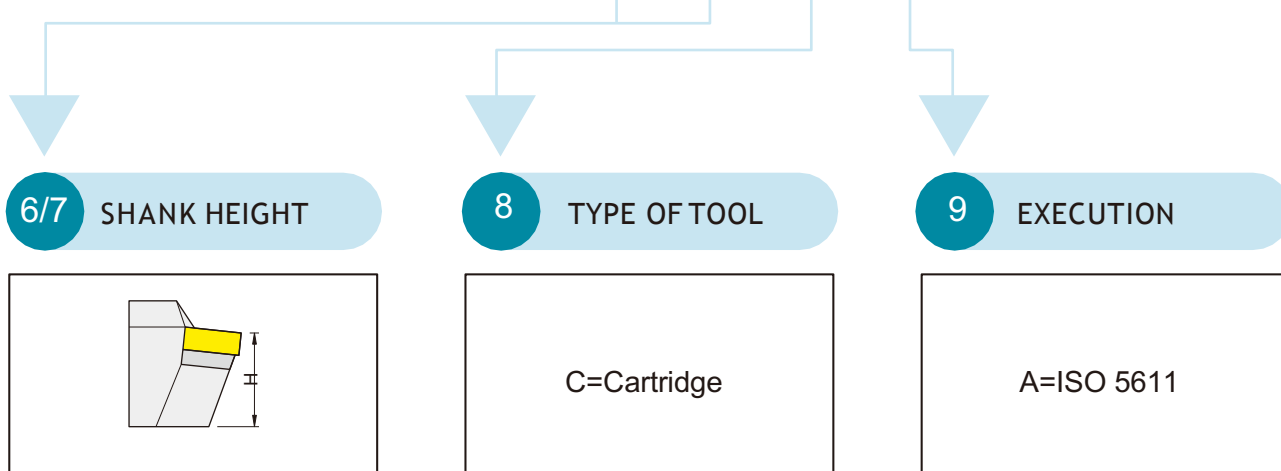

內徑車刀
BORING BARS

外徑車刀
TOOL HOLDERS

牙刀及開槽刀
THREADING & GROOVING

銑刀
MILLING

孔加工
BORING TOOLS COMPONENTS

配件
SPARE PARTS

C	N	M	G
1	2	3	4

12	04	08	(E)	(N)	(MR)
5	6	7	8	9	10

1 刀片形狀 INSERT SHAPE

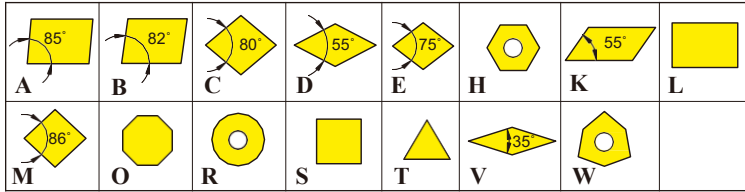

2 刀片逃角 CLEARANCE ANGLE

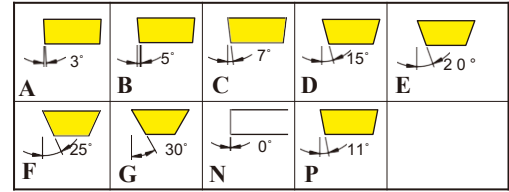

3 刀片公差 TOLERANCES CLASS

	Tolerance		
	d±	m±	s±
A	0.025	0.005	0.025
C	0.025	0.013	0.025
E	0.025	0.025	0.025
F	0.013	0.005	0.025
G	0.025	0.025	0.05-0.13
H	0.013	0.013	0.025
J	0.05-0.15	0.005	0.025
K	0.05-0.15	0.013	0.025
L	0.05-0.15	0.025	0.025
M	0.05-0.15	0.08-0.2	0.05-0.13
N	0.05-0.15	0.08-0.2	0.025
U	0.08-0.25	0.13-0.38	0.13

4 刀片溝孔 INSERT FEATURES

A		
C		
F		
G		
H		
J		
M		
N		
Q		
R		
T		
U		
W		
X	Special shape	

5 刀片邊長 EDGE LENGTH

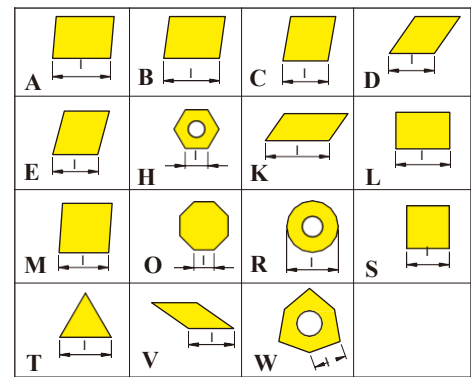

8 刀口角度 CUTTING EDGE

E	F	T	S
Rounded	Sharp	Chamfered	Chamfered and rounded

6 刀片厚度 TIP THICKNESS

Index	01	T1	02	03	T3	04	05	06	07	09
S(mm)	1.59	1.98	2.38	3.18	3.97	4.76	5.56	6.35	7.94	9.52

9 刃口方向 CUTTING DIRECTION

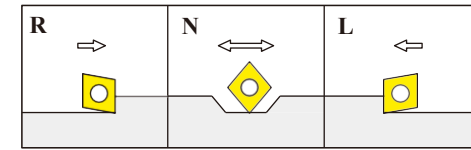

7 刀尖R角 CORNER RADIUS

Index	02	04	08	12	16	24	00	00:Round insert (inch)
r(mm)	0.2	0.4	0.8	1.2	1.6	2.4	0	MO:Round insert (metr)

10 排屑槽 Manufacturer's type designation

Chip breaker design

-MG -M -MR -D -DK